

FLASHWAVE[®] 4100

Multiservice Provisioning Platform



The FLASHWAVE 4100 MSPP family ensures a smooth migration of Ethernet services onto an embedded SONET infrastructure. These systems offer field-proven optical access and transport combined with a powerful, flexible mix of Carrier Ethernet and SONET-derived services from DS1 to OC-48.

FLASHWAVE® 4100

Multiservice Provisioning Platform

Optimal edge convergence

The FLASHWAVE® 4100 Multiservice Provisioning Platform (MSPP) family offers field-proven optical access and transport combined with a powerful, flexible mix of Carrier Ethernet and SONET derived services from DS1 to OC-48. The platform assures smooth migration of Ethernet services onto an embedded SONET infrastructure by converging packet mapping capabilities over SONET. The system supports a wide variety of MEF-9 and MEF-14-certified E-Line and E-LAN services, providing:

- Flexible 1 Mbps bandwidth provisioning granularity
- Efficient statistical multiplexing for oversubscription
- Ethernet aggregation
- Class-of-service differentiation
- SONET reliability
- 0:2 and LCAS offers 2x throughput

Bridging the transition to packet services

The FLASHWAVE 4100 MSPP compliments existing investments and minimizes capital and operational outlay. Available in two form factors, the platform offers a wide range of customers an optimal combination of price, footprint and industry-leading service provisioning capabilities.

The FLASHWAVE 4100 product family provides extensive Ethernet capabilities (10/100Base-T and 100 and 1000Base-X). It offers an excellent solution for operators transitioning to a more packet-centric network while still providing important revenue-bearing legacy OC-n/ TDM services.

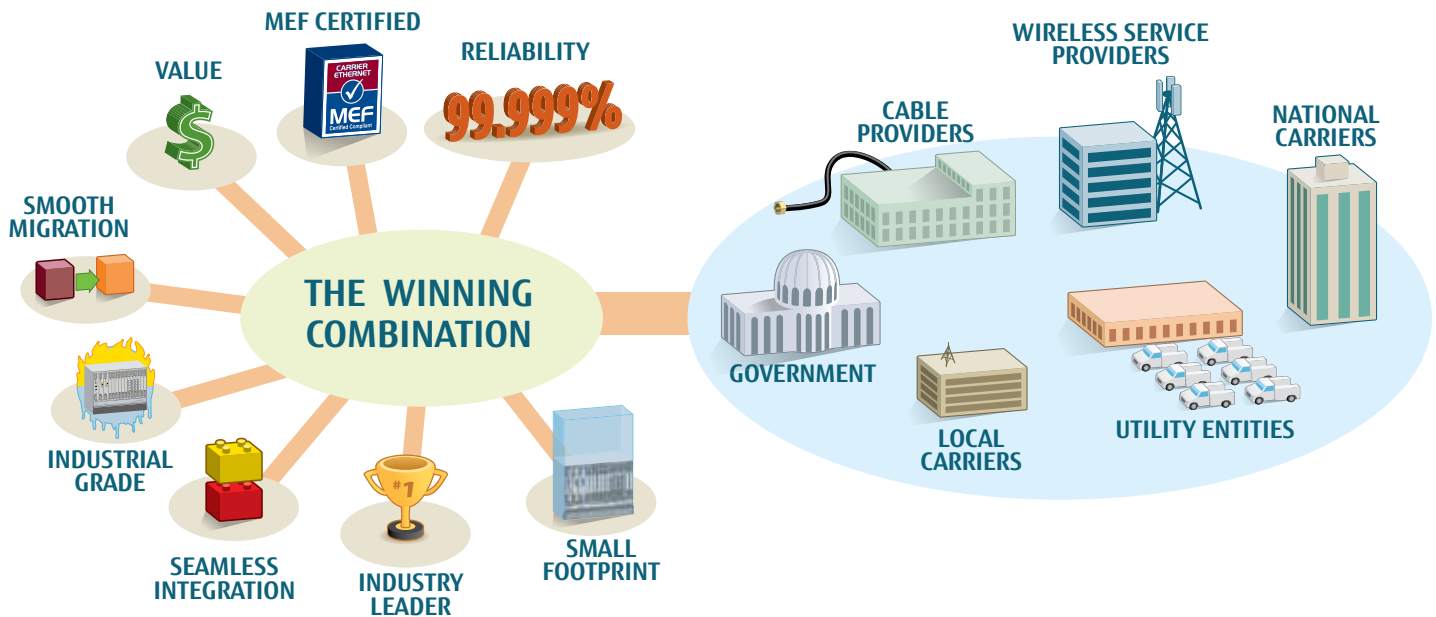

Adaptable and rugged

The temperature-hardened FLASHWAVE 4100 MSPP offers carrier-class availability for DS1, DS3/EC1, DS3 Transmux, 10/100/1000 Ethernet, OC-3 and OC-12 service delivery over OC-3/12/48 UPSR, 1+1 or 0:2 facilities. The platform is used in Central Office (CO), controlled environmental vault, remote terminal and at customer locations in racks, cabinets and wall-mount configurations. Its high capacity and non-blocking STS and VT switch fabric enables optical hub operation for converged wireline and wireless access networks. As a compact Digital Cross-connect system (DCS), the platform provides efficient grooming in remote COs and cell sites.

The Large Shelf version of the FLASHWAVE 4100 MSPP offers Layer 2 Ethernet support for E-Line and E-LAN connectivity and differentiated classes of service. The FLASHWAVE 4100 Small Shelf, with its integrated secure enclosure, offers half the number of service interface slots as the Large Shelf. It is designed for CPE locations that require all-front access, AC operation and integral battery backup.

Multiple service provisioning technologies

The FLASHWAVE 4100 MSPP converges GFP, LO- and HO-VCAT, LCAS, RPR and VLAN tagging on a single platform. It ensures superior flexibility for provisioning data services:

- SONET resiliency
- Resilient Packet Ring (RPR) efficiency
- Advanced Carrier Ethernet
- 802.1q VLAN tagging

Business CPE

A wide array of DS-1/3, OC-3/12 and Ethernet service interfaces ensures cost-effective, efficient solutions for business access applications. Modular shelf options, combined with multiple options for racks and secure indoor and outside plant cabinets, provides the flexibility needed for the business services market. Support for CWDM, and OC-48 DWDM network optics, as well as standard 1310 nm versions, ensures efficient operation even when the fiber plant is highly constrained.

Business park services

The FLASHWAVE 4100 product family is fully temperature-hardened and offers multiple industry-certified outside plant cabinet options. This makes it the best solution for providing TDM, SONET and optical Ethernet services for business parks.

Field-proven optical access and transport with a wide variety of services

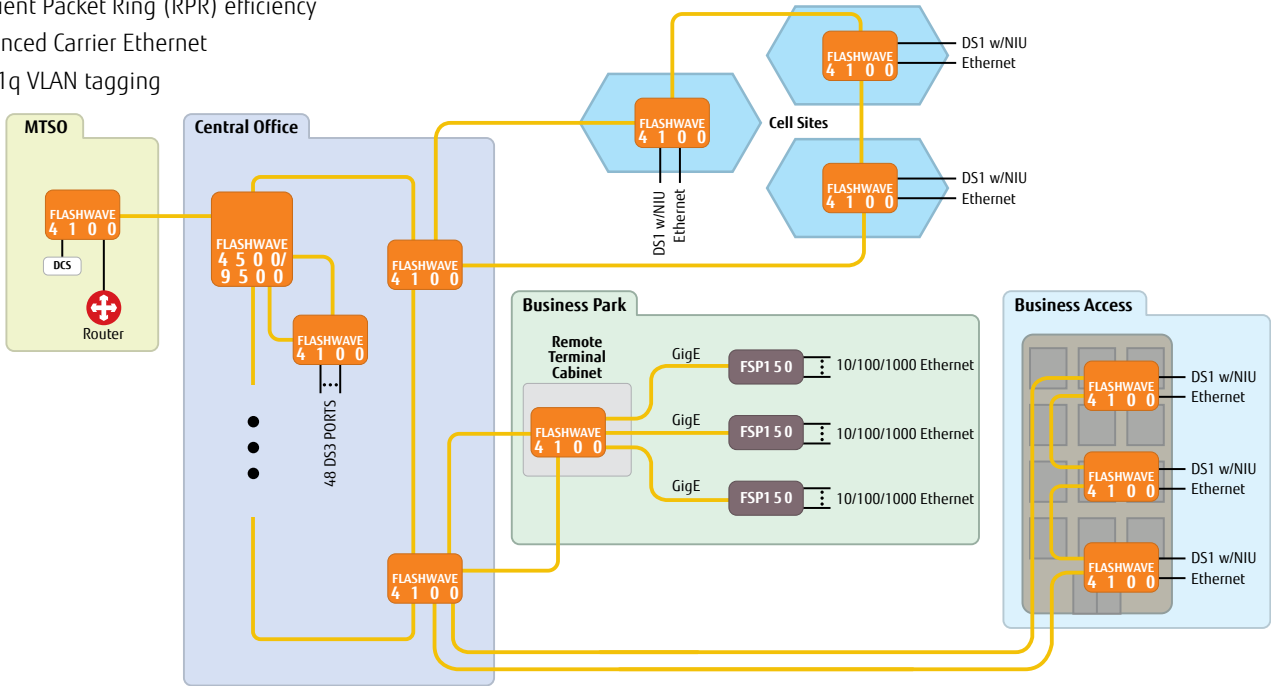

FLASHWAVE® 4100

Multiservice Provisioning Platform

Network life cycle services

Fujitsu offers a broad selection of professional services to assist at every stage in a network's evolution and operation. From planning through deployment and ongoing maintenance to future enhancements, Fujitsu Network Life Cycle Services are available whenever needed. Our comprehensive range of services includes network and system design, training, customized deployment, craft interface software, migration planning and more. Fujitsu sales representatives can guide service providers in selecting service options that address individual business needs.

Popular planning and deployment services for the FLASHWAVE 4100 MSPP include:

- Custom Cabinet Solutions – Turnkey inside wall-mount and outside plant solutions, including standard and custom configurations for wireline, wireless, FTTx, cable and MSO customers
- Furnish Material – Identification and ordering of material needed to install network equipment such as electrical and fiber cable solutions, minor materials and third-party ancillary equipment
- Turn-Up and Test – From on-site configuration and simple turn-up to rigorous, long-term testing

Fujitsu Maintenance and Support Program

For a complete professional maintenance solution, the Fujitsu Maintenance and Support Program has the right combination of flexibility and comprehensive assurance. Choose the level and types of service you need to supplement your own resources. The Maintenance and Support Program helps keep your network running smoothly, provides critical care and protects the longevity of your investment.

Network Operations Center

With a full range of vendor-independent network fault and performance monitoring features, the Fujitsu Network Operations Center (NOC) offers guaranteed, round-the-clock system protection. Our reliable NOC facility is available as a primary or supplemental operations resource. This service not only helps you control costs and maintain high levels of customer satisfaction, it also provides trustworthy and reliable after-hours and emergency coverage.



Features and specifications

- Architectures**
- Terminal (1+1)
 - Linear ADM (1+1) (Large and Small Shelf only)
 - Unidirectional Path Switched Ring (UPSR)
 - 0:2 Both line cards working and unprotected

- Line interfaces**
- OC-3, OC-12 and OC-48 line interfaces
 - Standard versions have SC or LC connectors
 - SFP-based versions have LC connectors
 - 1310 or 1550 nm wideband
 - CWDM SFP optics
 - OC-48 DWDM SFP optics

- Service interfaces**
- DS1 with 36*- or 64-pin AMP® connectors
 - DS3/EC1 with BNC connectors
 - DS3 Transmux with BNC connectors
 - OC-3 and OC-12 (SFP) with LC connectors
 - 1310 or 1550 nm wideband
 - CWDM SFP optics
 - 10/100Base-T with RJ-45 connectors
 - 100Base-X (SFP) with LC connectors
 - 1000Base-X (SFP) with LC connectors

* Mix of 36- and 64-pin AMP connectors on FLASHWAVE 4100 Small Shelf, all others are 64-pin AMP

Protection options

DS1	1:1 or unprotected
DS3/EC1	1:1 or unprotected
DS3 Transmux	1:1 or unprotected
SONET	1+1, UPSR or 0:2 dual working unprotected
Ethernet (all)	Unprotected

Switching

	STS-1 TSI	VT1.5 TSI
OC-3 line interface	42 x 42	1176 x 1176
OC-12 line interface	168 x 168	4704 x 4704
OC-48 line interface	240 x 240	6720 x 6720

Maximum number of service interfaces (large shelf)

	Ports/card	Unprotected ports/shelf	Protected ports/shelf
Large Shelf (12 service interface slots)			
DS1	14	84	84
DS3/EC1	3	12	12
DS3 Transmux	3	12	12
OC-3	4	48	24
OC-12	1	12	6
10/100Base-T	4	48	-
100Base-X	4	24	-
1000Base-X	2	12	-

Maximum number of service interfaces (small shelf)

	Ports/card	Unprotected ports/shelf	Protected ports/shelf
Small Shelf (6 service interface slots)			
DS1	14	42	42
DS3/EC1	3	6	6
DS3 Transmux	3	6	6
OC-3	4	24	12
OC-12	1	6	3
10/100Base-T	4	24	-
100Base-X	4	24	-
1000Base-X	2	6	-

FLASHWAVE® 4100

Multiservice Provisioning Platform

Features and specifications

- Synchronization**
- DS1/E1 Building Integrated Timing Supply (BITS) primary and secondary clock input/output *
 - Line timing
 - Synchronization Status Messaging (SSM)
 - Internal Stratum 3 timing source
- * Large Shelf includes timing input and output, Small Shelf supplies timing output only*

- Operations**
- TL1 protocol over X.25, OSI/Ethernet or IP/Ethernet
 - SNMP monitoring
 - NETSMART® 500 Element Manager
 - NETSMART 1500 Management System
 - TCP/IP and X.25 gateway functionality (Large Shelf only)
 - Software download and remote memory backup/restore
 - Interoperable with all Fujitsu transmission products
 - Telcordia™ OSMINE certified
 - NEBS Level 3 certified
 - UL listed

Operating environment	Temperature	<ul style="list-style-type: none"> • SONET TDM • -40 to +65 °C (-40 to +149 °F) • Ethernet • 0 to 55 °C (32 to 131 °F)
	Humidity	5 to 95% (non-condensing)

Power consumption		
	Large Shelf	Small Shelf
Maximum power consumption	484 W	292 W
Heat dissipation	1652 BTU/hr	997 BTU/hr
Power input	-48 V DC	-48 V DC or 110 V AC

Physical characteristics		
	Large Shelf	Small Shelf
Shelf dimensions (H x W x D)	14 x 17.5 x 12" (35.6 x 44.5 x 30.5 cm)	11.5 x 18.75 x 10.75" (29.3 x 47.7 x 27.4 cm)
Weight (fully-loaded)	75 lb (34 kg)	38 lb (17 kg)



Fujitsu Network Communications Inc.
 2801 Telecom Parkway, Richardson, TX 75082
 Tel: 800.777.FAST (3278) Fax: 972.479.6900
us.fujitsu.com/telecom

© Copyright 2011 Fujitsu Network Communications Inc.
 FLASHWAVE™ is a trademark of Fujitsu Network Communications Inc. (USA).
 FUJITSU (and design)™ and "shaping tomorrow with you" are trademarks of Fujitsu Limited.
 All Rights Reserved. All other trademarks are the property of their respective owners.
 Configuration requirements for certain uses are described in the product documentation.
 Features and specifications subject to change without notice.

**EQUIPMENT
FOR SALE**

FUJITSU EQUIPMENT

Flash-192 | Flashwave 4100 | Flashwave 4500 | FLASH 2400 ADX
Flashwave 7700 | Flashwave 9500 | Flashwave CDS | FLM 2400



FUJITSU

**Contact Today
For Current Inventory**

Visit TELECOMCAULIFFE.com

✓ **REDUCING LEADTIMES** ✓ **COST SAVINGS** ✓ **LIFETIME WARRANTY** ✓ **SUSTAINABLE SOLUTIONS**

PICS | **TELECOMCAULIFFE**
A PICS TELECOM TEAM

BILL MCAULIFFE
Director of Sales – National Accounts

TEAMMCAULIFFE@PICSTELECOM.COM | 585.746.6383 | TELECOMCAULIFFE.COM

* This document contains confidential and proprietary information that is the property of PICS Telecom International, which is provided for the sole purpose of permitting the recipient to respond to this Equipment Sale flyer. No part of this document is to be used without written permission by PICS Telecom. All trademarks, trade names, photos, or logos mentioned or used are the property of their respective owners and are intended solely for identification purposes.