

# 3931



Ciena's 3931 Platform is a weatherproof advanced Carrier Ethernet system able to deliver Carrier Ethernet services to almost any environment without sacrificing leading-edge functionality. The 3931 incorporates a complete Operations, Administration, and Maintenance (OAM) suite to support the network and service performance monitoring requirements of large-scale Ethernet deployments while reducing network operating costs.

The 3931 also provides sophisticated Quality of Service (QoS) capabilities and synchronization features for a complete mobile backhaul and Ethernet business services solution. The weatherproof housing of the 3931 enables an exceptionally low TCO for operators by eliminating the associated costs of cabinets, enclosures, and site preparation.

The 3931 software architecture is based on the common Service-Aware Operating System (SAOS) used in all Ciena service delivery and service aggregation switches to provide advanced Carrier Ethernet features, with consistent system and service attributes to improve operational efficiency. The 3931 leverages the SAOS to deliver Ethernet services cost-effectively to a multitude of environments and applications, including Long Term Evolution (LTE) mobile backhaul, utilities and smart grid, and Ethernet business services.

The 3931 provides advanced Carrier Ethernet in a fully self-contained and weatherproof form factor. By adhering to Class 4 of GR-3108 Issue 2 Network Equipment in the OutSide Plant (OSP), the 3931 can withstand heat, cold, and precipitation and enable rapid deployment of advanced Carrier Ethernet service delivery in virtually any location, without requiring costly OSP cabinets. By eliminating these site engineering and infrastructure costs, the service start-up cost of deploying the 3931 is unparalleled and dramatically expands the profitable addressable market for operators.

## Features and Benefits

- Includes environmentally-hardened and physically secure enclosure and electronics (-40°C to +70°C), enabling Carrier Ethernet service delivery to virtually any location
- Provides advanced Carrier Ethernet and low Total Cost of Ownership (TCO), powered by Ciena's SAOS
- Supports 2 1GbE/10GbE NNI ports to deliver exceptional capacity for bandwidth-hungry applications
- Supports 8 GbE UNI ports including 4 100/1000Base-X Small Form-factor Pluggable (SFP) ports and 4 RJ-45 10/100/1000 Base-TX ports
- Provides IEEE 1588v2 and Synchronous Ethernet to ensure high-quality and reliable transport services for mobile backhaul and LTE
- Incorporates on-board RFC 2544 Performance Benchmark testing capabilities, enabling end-to-end SLA verification without a truck roll
- Includes flexible mounting capabilities: pole mount, H-Frame mount, and outdoor or indoor wall mount

As bandwidth demands continue to grow exponentially, particularly for mobile backhaul applications, the 3931 provides the ability to deploy with 1G backhaul today and simply swap transceivers to upgrade to 10G when the rest of the network is ready. Readiness for LTE and future mobile backhaul needs are not compromised. The 3931 features a high-capacity switching fabric, 2 NNI SFP+ ports that support 1GbE or 10GbE, 4 100/1000M SFP UNI ports, and 4 10/100/1000 RJ-45 UNI ports.



Figure 1. 3931 interior view

Additional features of the 3931 streamline installation, extend service life, and ensure universal applicability:

- Door-on-door architecture provides end-customer access to the UNI demarcation compartment while restricting access to the rest of the system to the operator’s qualified personnel
- Universal power options for DC applications (+24/-24/-48V), AC applications (100-240V), and simplex or duplex powering
- External alarm inputs enabling environmental monitoring, including doors and rectifiers

Ciena’s SAOS delivers consistent benefits across all Ethernet access and aggregation applications, including:

- Rapid implementation of the latest advances in Ethernet technologies, as well as new services and standards proposed by the IEEE, the IETF, MEF, and ITU
- Interoperability with Ethernet equipment from other vendors
- Improved efficiency and cost savings resulting from a common deployment and service provisioning model
- Service offering ubiquity, permitting rapid rollout of new services across the entire network
- Complete MEF-compliant Ethernet service offerings
- Ethernet Private Line, Ethernet Private LAN
- Ethernet Virtual Private Line, Ethernet Virtual Private LAN
- Conforming to MEF 9 and MEF 14

### G.8032 Ethernet Ring Protection Switching

The 3931 supports multiple resiliency options, including G.8032 Ethernet Rings. G.8032 provides deterministic sub-50 ms protection switching, enabling operators to deliver carrier-grade Ethernet services and attain the resiliency capabilities of the legacy SONET infrastructure without the associated costs. Ciena’s solution is highly scalable, permitting the number of network elements on the ring to increase as needs grow. Additionally, ring bandwidth can be based on 1GbE or 10GbE, and even include ring spans based on other service layer technologies and speeds—permitting exceptional flexibility for operators to create G.8032 rings and provide sub-50 ms resiliency.

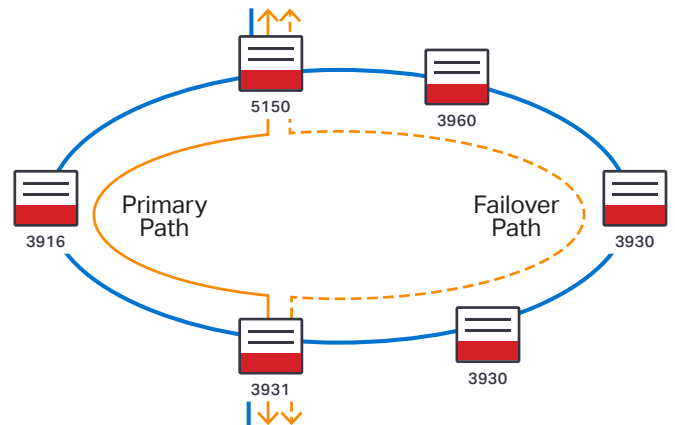

Figure 2. G.8032 ring

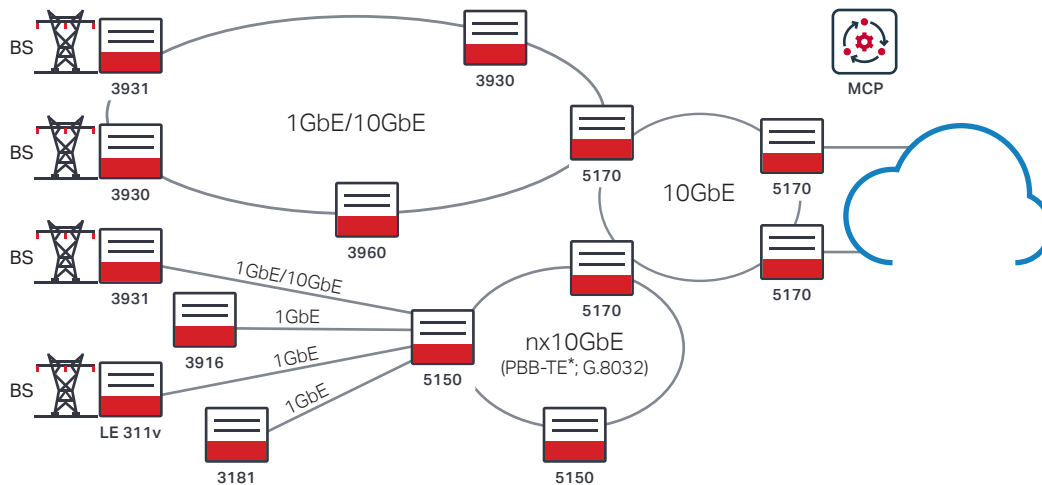

Figure 3. Sample CES architecture for mobile backhaul enabling Ethernet for 2G, 3G and 4G networks

### Synchronization and Timing

The cost-effectiveness and versatility of Carrier Ethernet are driving the convergence of services. Many services place new timing and synchronization requirements on the Ethernet network. The 3931 includes the capabilities to address the maintenance of highly accurate synchronization across the network. This synchronization includes:

- IEEE 1588v2 Precision Time Protocol
- ITU-T G.8262 Synchronous Ethernet
- Stratum-3E Holdover

These features enable carriers to provide SONET/SDH-like Layer 1 timing while decommissioning those expensive secondary networks. The need for accurate synchronization is most pronounced for mobile backhaul applications.

The 3931 excels in mobile backhaul, addressing the needs of multiple generations of wireless technology, especially the needs of LTE, where no TDM interfaces exist, but very accurate frequency and phase synchronization are mandatory.

### Simplified multi-layer management and control

Ciena's Manage, Control and Plan (MCP) domain controller software offers a unique and comprehensive solution for the administration of mission-critical networks that span access, metro, and core domains, and provides unprecedented

multi-layer visibility from the photonic to the packet layers. With this innovative management approach, MCP supports a programmable and automatable solution that provides a fully open approach to installing, manipulating, and monitoring service behaviors in an SDN environment.

### Carrier Ethernet QoS

The 3931 implements true carrier-class, MEF-14-compliant QoS that permits delivery of a wide range of traffic types and rates over a single access infrastructure without interference or degradation. These capabilities enable greater revenue generation by utilizing available network resources efficiently, while improving customer relations with enforceable and reliable Service Level Agreements (SLAs). These capabilities are enabled by:

- Eight hardware queues/port, up to 64 ingress meters per port
- Two rate Three Color Metering (trTCM), marking, policing, shaping
- Per-port, per-VLAN QoS with CIR/EIR settings
- Random Early Detection (RED), flexible Deficit Weighted Round Robin (DWRR) and Strict Priority Scheduling
- Hierarchical QoS (H-QoS)

The 3931 enables automated service provisioning, resulting in a more comprehensive deployment of QoS at a significantly lower cost.

<b>Turn up Acceptance and SLA Conformance Testing</b>	IETF RFC 2544 Generator/Reflector ITU-T Y.1564 Generator/Reflector
<b>Layer 3 SLA Monitoring and Metrics: Delay, Jitter</b>	IETF RFC 5357 TWAMP Two-Way Active Measurement Protocol
<b>Layer 2 SLA Monitoring and Metrics: Delay, Jitter, Frame Loss</b>	ITU-T Y.1731 Ethernet OAM
<b>Service Heartbeats, End-to-End and Hop-by-Hop fault detection</b>	IEEE 802.1ag CFM Connectivity Fault Management
<b>Enhanced troubleshooting, rapid network discovery</b>	IEEE 802.3ah EFM Physical Link

Figure 4. Ciena's 3931 OAM suite

## Industry-leading OAM Suite

Successful Carrier Ethernet service deployments require an effective strategy to monitor the health and performance of the network and end-customer EVCs. The approach to OAM can make or break the business case, as customers demand expanded SLA verification and inefficient approaches drive OPEX.

Ciena's portfolio has a strong OAM feature suite that provides comprehensive link, service, and network monitoring and performance metrics. OAM features available today include:

- IEEE 802.1ag Connectivity Fault Management (CFM)
- IEEE 802.3ah Ethernet in the First Mile (EFM)
- IEEE 802.1AB Link Layer Discovery Protocol (LLDP)
- ITU-T Y.1731 Performance Monitoring: Delay, Jitter, Loss
- IETF RFC 5618 TWAMP Sender and Responder for L3 SLA Monitoring
- IETF RFC 2544 Performance Benchmarking Test Generation and Reflection

The 3931 integrates RFC 2544 Performance Benchmarking generation and reflection capabilities directly within the service delivery switch, enabling exceptional OPEX saving. Most mobile operators and other demanding end-customers require performance test and characterization before service acceptance.

Typically, this testing is performed by technicians with expensive handheld test sets, leading to scheduling delays and associated high OPEX costs.

Ciena's low-touch turn up simplifies system turn up and enables 2544 performance testing to be run from the Network Operations Center (NOC). This efficiency minimizes service personnel costs and ensures consistent, reproducible test reports ready for immediate transmission to the customer for service acceptance.

A built-in RFC 2544 also empowers the operator to be highly responsive to service disruptions. When service impacts are detected by ongoing PM tests (Y.1731 or TWAMP) or upon report by the end-customer, performance tests can be initiated immediately by the NOC; no technician scheduling is required, no trucks are rolled. Testing to isolate and localize the issue and then focus resources on addressing the specific root cause can occur at virtually no cost. This responsiveness means troubles are fixed faster, minimizing service impact and creating higher customer satisfaction.

The 3931 enhances the RFC 2544 standard by providing additional metrics like Packet Delay Variation (PDV), including more expedient test suite results and architecting to the ITU-T Y.1564 standard for even greater capabilities.

## Technical Information

### Interfaces

2 x 1/10G SFP+ NNI/UNI ports  
4 x 100/1000M SFP UNI ports  
4 x 10/100/1000M RJ-45 UNI ports  
1 x Console Port (RJ-45, EIA-561)  
5 x External Alarm Inputs

### Ethernet

IEEE 802.3 Ethernet  
IEEE 802.3u Fast Ethernet  
IEEE 802.3z Gigabit Ethernet  
IEEE 802.1D MAC Bridges  
IEEE 802.1Q VLANs - Including .1p Priority  
IEEE 802.1ad Provider Bridging (Q-in-Q) VLAN full S-VLAN range  
VLAN tunneling (Q-in-Q) for Transparent LAN Services (TLS)  
Per-VLAN MAC Learning Control  
Per-Port MAC Learning Control  
IEEE 802.3ad Link Aggregation Control Protocol (LACP)  
ITU-T G.8032 Ethernet Ring Protection Switching  
Jumbo Frames to 9216 bytes  
Layer 2 Control Frame Tunneling

### Multicast Management

RFC 2236 IGMPv2 Snooping  
IGMP Domains  
IGMP Message Filtering  
IGMP Inquisitive Leave  
Broadcast/Multicast Storm Control  
Unknown Multicast Filtering  
Well-known Protocol Forwarding

### Quality of Service

8 Hardware Queues per-Port  
Committed and Excess Information Rate (CIR and EIR)  
Classification based on IEEE 802.1D priority VLAN, source port, destination port, TCP/UDP port  
IP Precedence and IPDSCP  
Layer 2, 3 Quality of Service  
Ingress metering per-port  
Ingress metering per-port per-CoS  
Ingress metering per-port per-VLAN  
Up to 64 Ingress Meters per-port  
Up to 512 Ingress Meters per-system  
C-VLAN Priority to S-VLAN Priority Mapping  
S-VLAN Priority based on C-VLAN ID  
Per-VLAN Classification, Metering, and Statistics  
Per-port, per-VLAN QoS with CIR and EIR traffic on Egress Queues

### Carrier Ethernet OAM

IEEE 802.1ag Connectivity Fault Management (CFM)  
IEEE 802.3ah Ethernet in the First Mile (EFM)  
IEEE 802.1AB Link Layer Discovery Protocol (LLDP)  
ITU-T Y.1731 Performance Monitoring  
RFC 2544 Performance Benchmarking Test Generation and Reflection  
ITU-T Y.1564-compliant architecture  
RFC 5618 TWAMP Responder and Receiver  
TWAMP Sender  
TWAMP +/- 1ms timestamp accuracy  
Dying Gasp with Syslog and SNMP Traps

### MPLS/VPLS

RFC 2205, 3031, 3036, 3985 MPLS Pseudowire Emulation Edge-to-Edge (PWE3)  
RFC 3916, 3985, 4446, 4447, 4448 Pseudowires  
RFC 5654 MPLS-Transport Profile  
MPLS Virtual Private Wire Service (VPWS)  
RFC 4664, 4665 L2VPNs  
RFC 4762 VPLS (Virtual Private LAN Service) and Hierarchical VPLS (H-VPLS)  
Provider Edge (PE-rs) Functionality for VPLS and H-VPLS  
PE-rs Functionality with Spoke and Mesh Virtual Circuits  
MTU-s Functionality for H-VPLS deployment  
MTU-s Multihoming (redundant VCs to different PE-s switches)  
MPLS Virtual Circuit as H-VPLS spoke Virtual Circuit  
PBB-TE Service Instance as H-VPLS spoke Virtual Circuit  
Q-in-Q Ethernet Virtual Circuit as H-VPLS spoke Virtual Circuit  
MPLS Label Switch Path (LSP) Tunnel Redundancy  
Layer 2 Control Frame Tunneling over MPLS Virtual Circuits  
RFC 3209 RSVP-TE (for MPLS Tunnel Signaling)  
RFC 3630 OSPF-TE (for MPLS Tunnel Routes)  
RFC 3784 IS-IS-TE (for MPLS Tunnel Routes)  
RFC 3036 Targeted LDP (for VPLS VC signaling)  
RFC 4090 MPLS Fast ReRoute (via RSVP-TE)  
MPLS Performance Monitoring  
RFC 4379 LSP Ping  
RFC 4379 LSP Traceroute  
RFC 5085 LSP Ping and Traceroute extensions to work over Pseudowires (PW VCCV)

### PBB-TE (Provider Backbone Bridging - Traffic Engineering)

IEEE 802.1Qay PBB-TE  
IEEE 802.1ah PBB frame format  
PBB-TE Multi-homed Protection Failover  
IEEE 802.1ag CFM for PBB-TE Tunnels  
IEEE 802.1ag CFM for PBB-TE Service Interfaces  
PBB-TE Full B-VID & I-SID address ranges  
PBB-TE Tunnel & Service metering

### Service Security

Egress Port Restriction  
IEEE 802.1X Port-Based Network Access Control (RADIUS/MD5)  
Layer 2, 3 Protocol Filtering  
Broadcast Containment  
User Access Rights  
Per-port or per-VLAN Service Access Control  
Hardware-based DOS Attack Prevention  
Hardware-based Access Control Lists (ACLs)

### Network Management

Enhanced CLI  
CLI-based configuration files  
SNMP v1/v2c/v3  
SNMPv3 Authentication and Message Encryption  
RFC 1213 SNMP MIB II  
RFC 1493 Bridge MIB  
RFC 1643 Ethernet-like Interface MIB  
RFC 1573 MIB II interfaces  
RFC 1757 RMON MIB - including persistent configuration  
RFC 2021 RMON II and RMON Statistics  
Per-VLAN Statistics  
RADIUS Client and RADIUS Authentication  
TACACS + AAA  
RFC 2131 DHCP Client  
RFC 1305 NTP Client  
RFC 1035 DNS Client  
Telnet Server  
RFC 1350 Trivial File Transfer Protocol (TFTP)  
RFC 959 File Transfer Protocol (FTP)  
Secure File Transfer Protocol (SFTP)  
Secure Shell (SSHv2)  
Syslog with Syslog Accounting  
Port State Mirroring  
Local Console Port  
Comprehensive Management via Ethernet Services Manager  
Remote Autoconfiguration via TFTP, SFTP  
Software download/upgrade via TFTP, SFTP

## Technical Information continued

### MAC Address Table Capacity

32,000 MAC addresses

### Power Requirements

DC Input: -48, -24, +24 VDC (nominal)

AC Input: 100V, 240V AC (nominal)

AC Frequency: 50/60 Hz

Maximum Power Input: 60 W

### Agency Approvals

**Safety:** UL/CSA 60950-1-07; IEC 60950-1:2005 (2nd edition); EN 60950-1:2006

**Emissions:** FCC Part 15 (2009); EN55022 (2006 +A1 2006); AS/NZS CISPR 22 (2006); CISPR 22 (2005 + A1 2005); ICES-003 Issue 4 (2004); EN 61000-3-2 (2006); EN 300 386 (v1.4.1, 2008); EN 300 132-2 (2007-10); EN 300 132-3 (2003-08)

**Environmental:** WEEE 2002/96/EC  
RoHS 2002/95/EC

**Immunity:** CISPR 24 (1997, +A1 2001 + A2 2002); EN 55024 (1998 + A1 2001 + A2 2003); EN 300 386 (v1.4.1, 2008); EN 61000-4-11 (2005); EN 61000-3-3 (2008); EN 300 132-2 (2007-10); EN 300 132-3 (2003-08)

**Laser Safety:** CDRH Letter of Approval (US FDA Approval); FCC 21 CFR subpart (J) (Safety of Laser Products); IEC 60825-1:2007

### Environmental Characteristics

GR-63-CORE, Issue 3 – NEBS Level 3

GR-1089 Issue 5 – NEBS Level 3

GR-950 Issue 2 Optical Network Unit

GR-3108 Issue 2 Network Equipment in the Outside Plant (OSP) Class 4

ETSI 300 019 Class 1.2, 2.2, 4.1

#### Operating Temperature:

-40°F to +158°F (-40°C to +70°C)

-40°F to +115°F + Solar Load

(-40°C to +46°C + Solar Load)

#### Storage Temperature:

-40°F to +158°F (-40°C to +70°C)

**Relative Humidity:** 5% to 100% (condensing)

### Physical Characteristics

#### Enclosure Dimensions:

16.8"(W) x 17.0"(H) x 7.0"(D)

427mm (W) x 431mm (H) x 178mm (D)

**Product weight:** 13.0 kg; 28.6 lbs

### Ordering Information

3931, enclosure, (1) slot for pluggable system module, (2) slots for AC or DC pluggable power supply; Part/Kit#: 120-3931-900

3931, pluggable system module, (2) 1G/10G SFP+, (4) 100/1000M SFP, (4) 10/100/1000M RJ-45; Part/Kit#: 170-3931-900

3931, sync pluggable system module, (2) 1G/10G SFP+, (4) 100/1000M SFP, (4) 10/100/1000M RJ-45; Part/Kit# 170-3931-910

3931, DC pluggable power supply, wide range 24/48V; Part/Kit#: 170-0041-900

3931, AC pluggable power supply, wide range 120/240V; Part/Kit#: 170-0042-900

3931, fiber demarcation jumper, (1) SC multimode UNI port; Part/Kit#: 170-0043-900

3931, fiber demarcation jumper, (1) SC multimode UNI port; Part/Kit#: 170-0049-900

Visit the Ciena Community  
Answer your questions



**EQUIPMENT  
FOR SALE**

# Ciena 3930 Service Delivery Switches & 3931 Weatherproof Carrier Ethernet Systems



**170-3930-900 | 170-3931-900**

**ciena**

**QTY 500+  
Available!**

**Contact Today  
For Current Inventory**

Visit [TELECOMCAULIFFE.com](http://TELECOMCAULIFFE.com)



✓ **REDUCING LEADTIMES**    ✓ **COST SAVINGS**    ✓ **LIFETIME WARRANTY**    ✓ **SUSTAINABLE SOLUTIONS**

**PICS** | **TELECOMCAULIFFE**  
A PICS TELECOM TEAM

**BILL MCAULIFFE**  
*Director of Sales – National Accounts*

[TEAMCAULIFFE@PICSTELECOM.COM](mailto:TEAMCAULIFFE@PICSTELECOM.COM) | 585.746.6383 | [TELECOMCAULIFFE.COM](http://TELECOMCAULIFFE.COM)

\* This document contains confidential and proprietary information that is the property of PICS Telecom International, which is provided for the sole purpose of permitting the recipient to respond to this Equipment Sale flyer. No part of this document is to be used without written permission by PICS Telecom. All trademarks, trade names, photos, or logos mentioned or used are the property of their respective owners and are intended solely for identification purposes.